

CSUM355 Intelligent addressable shop monitor unit



An extensive range of interfaces are available to support Eaton's range of control panels, providing solutions for most design requirements.

The shop monitor unit (CSUM355) is designed to enable small units with conventional fire detection to be fully integrated with a main intelligent addressable fire system.

This unit is ideal for applications such as connecting individual shop units into a main shopping centre system.

An external power supply is required to drive the 2 conventional sounder circuits. This power supply must be regulated for fire equipment and current limited.

Features and benefits

- Soft addressed
- Integral short circuit isolator
- Single address
- Provides 2 conventional sounder circuits
- Accepts a zone of Eaton's conventional detectors and a zone of conventional callpoints
- Inputs monitored for open, short circuits and earth contact faults
- Quick and simple to install
- No hard addressing required (plug and play)
- Easy to expand a system using existing wiring
- Reduced installation cost by using the 2 sounder circuits

Specifier's guide

2.5 Standard interfaces

Technical specification

Code	CSUM355
Description	Shop monitor unit
Standards	EN54 Pt17 & Pt18 2005
Specification	
Operating voltage	15V dc to 30V dc
Quiescent current	3.4mA (max)
Quiescent load current	2.8mA (max)
Alarm current	8mA (max)
Zone circuits	
Number of input circuits	2
Zone circuit 1	Callpoints only
Zone circuit 2	Detectors and callpoints
Number of callpoints	Unlimited
Callpoint resistance	470Ω to 680Ω
Zone circuit 1 eol	6K8
Zone circuit 2 eol	Active EOL
Number of detectors	20 (max)
Short circuit fault threshold	150Ω
Open circuit fault threshold	N/A active EOL
Sounder circuits	
Number of sounder circuits	2
Load per output	300mA (max)
Sounder circuit 1 and 2 eol	12K
Environmental	
Operating temperature	-10°C to +60°C
Humidity (non condensing)	0 to 95% RH
Physical	
Construction	PC/ABS
Dimensions (H x W x D)	129mm x 180mm x 60mm
Weight	1kg
Ingress protection	IP40
Compatibility	
Suitable for use with	Eaton intelligent addressable fire systems

Dimensions

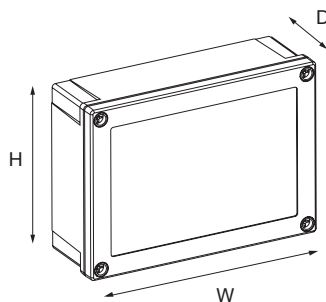

H (mm)	W (mm)	D (mm)
129	180	60

Standard connections

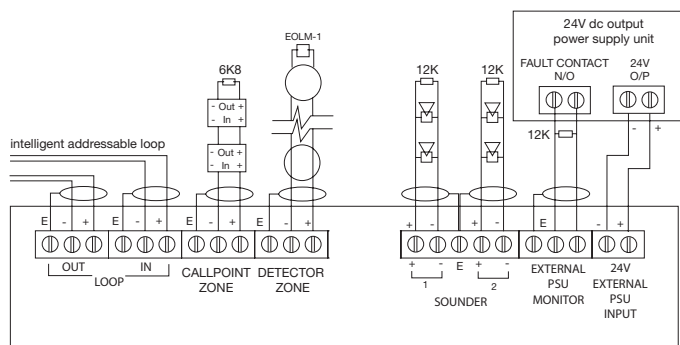

callpoints can be connected with detectors on detector zone if preferred

Catalogue numbers

Description	Code
Shop monitor unit	CSUM355